

# HWH® Automatic Touch Panel

725 Series touch-panel controller with automatic and manual controls



## Includes the following features...

- Easy-to-use touch panel controller for true automatic operation.
- Quick and easy leveling - no guesswork.
- One button gives you complete leveling sequence.
- Computer selects the most efficient way to level your RV.
- Touch buttons and yellow level indicator lights provide for manual operation if desired.
- Individual red jack-down indicator lights provided.
- 725 Series is identified by the blue LED Auto Level and Auto Store lights.



(On I-80, Exit 267 South) 2096 Moscow Road | Moscow, Iowa 52760

Phone: (800)321-3494 or (563)724-3396 | Fax: (563)724-3408 | Web: [www.HWH.com](http://www.HWH.com)

*Made in the USA*

**STRONG, RELIABLE, HYDRAULIC POWER**

**Installation Information**  
**HWH® Automatic Touch Panel**  
**725 Series touch-panel controller with automatic and manual controls**

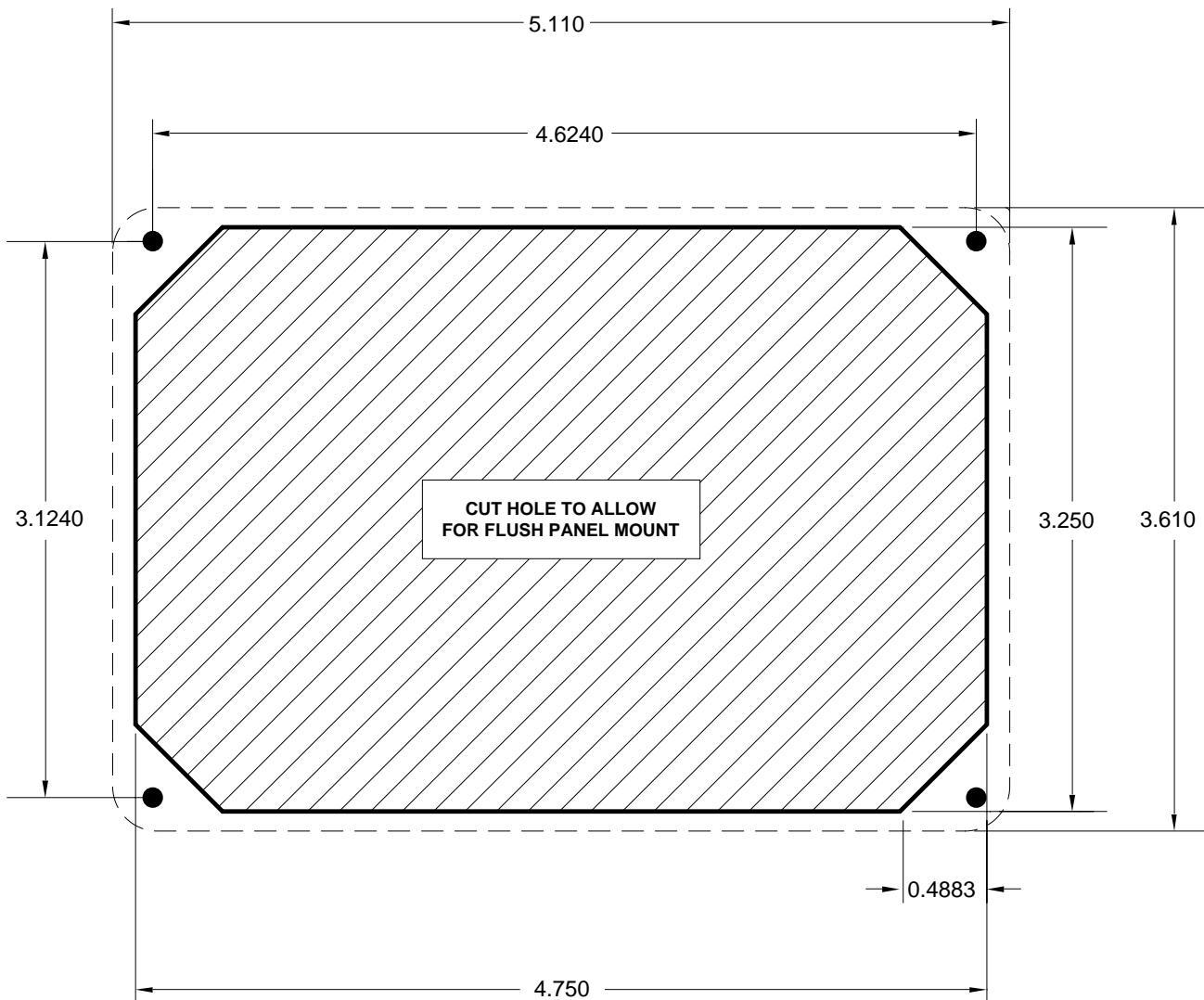

DASH LINE INDICATES OUTER BEZEL  
\* USE ACTUAL BEZEL FOR  
POSITIONING MOUNTING HOLES

