



RECORD THIS UNIT INFORMATION FOR  
 FUTURE REFERENCE:  
 Model Number \_\_\_\_\_  
 Serial Number \_\_\_\_\_  
 Date Purchased \_\_\_\_\_

**MODEL 630025.331**  
**Roof-Top Heat Pump**  
 used with  
**3106152.006 Mechanical Air Distribution Box**

**USA**  
 SERVICE OFFICE  
 Dometic Corporation  
 2320 Industrial Parkway  
 Elkhart, IN 46516  
 574-294-2511

**CANADA**  
 Dometic Corporation  
 46 Zatonski, Unit 3  
 Brantford, ON N3T 5L8  
 CANADA  
 519-720-9578

**For Service Center  
 Assistance Call:**  
 800-544-4881



**⚠ WARNING**

This manual must be read and understood before installation, adjustment, service, or maintenance is performed. This unit must be installed by a qualified service technician. Modification of this product can be extremely hazardous and could result in personal injury or property damage.

**⚠ AVERTISSEMENT**

Lire et comprendre ce manuel avant de procéder à l'installation, à des réglages, de l'entretien ou des réparations. L'installation de cet appareil doit être effectuée par un réparateur qualifié. Toute modification de cet appareil peut être extrêmement dangereuse et entraîner des blessures ou dommages matériels.

**INSTALLATION & OPERATING  
 INSTRUCTIONS**

**Model  
 630025.331**

REVISION:  
 Form No. 3309038.010 9/07  
 (Replaces 3309038.002)  
 (French 3309039.018)  
 ©2007 Dometic Corporation  
 LaGrange, IN 46761

**Important: These Instructions  
 must stay with unit.  
 Owner read carefully.**

## SAFETY INSTRUCTIONS

This manual has safety information and instructions to help users eliminate or reduce the risk of accidents and injuries.

### RECOGNIZE SAFETY INFORMATION



This is the safety-alert symbol. When you see this symbol in this manual, be alert to the potential for personal injury.

Follow recommended precautions and safe operating instructions.

### UNDERSTAND SIGNAL WORDS

A signal word, **WARNING OR CAUTION** is used with the safety-alert symbol. They give the level of risk for potential injury.

**! WARNING** indicates a potentially hazardous situation which, if not avoided, could result in death or serious injury.

**! CAUTION** indicates a potentially hazardous situation which, if not avoided may result in minor or moderate injury.

**CAUTION** used without the safety alert symbol indicates, a potentially hazardous situation which, if not avoided may result in property damage.

Read and follow all safety information and instructions.

## GENERAL INFORMATION

**A.** Product features or specifications as described or illustrated are subject to change without notice.

**B. This Air Conditioner Is Designed For:**

1. Installation on a recreational vehicle during the time the vehicle is manufactured.
2. Mounting on the roof of a recreational vehicle.
3. Roof construction with rafters/joists on minimum of 16 inch centers.
4. Minimum of 2.00 inches and maximum of 4.00 inches distance between roof to ceiling of recreational vehicle. Alternate installation methods will allow for roofs more than 4.00 inches thick.

**C.** The ability of the air conditioner to maintain the desired inside temperature depends on the heat gain of the RV. Some preventative measures taken by the occupants of the RV can reduce the heat gain and improve the performance of the air conditioner. During extremely high outdoor temperatures, the heat gain of the vehicle may be reduced by:

1. Parking the RV in a shaded area
2. Using window shades (blinds and/or curtains)
3. Keeping windows and doors shut or minimizing usage
4. Avoiding the use of heat producing appliances

Operation on High Fan/Cooling mode will give optimum or maximum efficiency in high humidity or high outside temperatures.

Starting the air conditioner early in the morning and giving it a "head start" on the expected high outdoor ambient will greatly improve its ability to maintain the desired indoor temperature.

For a more permanent solution to high heat gain, accessories like A&E outdoor patio and window awnings will reduce heat gain by removing the direct sun. They also add a nice area to enjoy company during the cool of the evening.

### D. Condensation

**Note:** The manufacturer of this air conditioner will not be responsible for damage caused by condensed moisture on ceilings or other surfaces. Air contains moisture and this moisture tends to condense on cold surfaces. When air enters the RV, condensed moisture may appear on the ceiling, windows, metal parts, etc. The air conditioner removes this moisture from the air during normal operation. Keeping doors and windows closed when this air conditioner is in operation will minimize condensed moisture on cold surfaces.

## SPECIFICATIONS

Model No.	Nominal Capacity (BTU/HR) Cooling	Electrical Rating	Compressor Rated Load Amps	Compressor Locked Rotor Amps	Fan Motor Rated Load Amps	Fan Motor Locked Rotor Amps	SCFM-High Speed Max/Min	Total Static Max/Min W.C.	Refrigerant R-22 (Oz.)	Minimum Wire Size*	AC Circuit Protection *** User Supplied	Installed Weight (Pounds)	Minimum Generator Size** 1 Unit/2 Units
630025.331	13,500	120VAC, 60 Hz., 1 PH	12.4	60.0	3.5	10.0	335/250	.012/0.65	23.5	12AWG Copper Up To 24'	20 Amp	99	3.5 KW /5.0 KW

\* For wire length over 24 ft., consult the National Electric Code for proper sizing.  
 \*\* Dometic Corporation gives **GENERAL** guidelines for generator requirements. These guidelines come from experiences people have had in actual applications. When sizing the generator, the total power usage of your recreational vehicle must be considered. Keep in mind generators lose power at high altitudes and from lack of maintenance.  
 \*\*\* **CIRCUIT PROTECTION:** Time Delay Fuse or HACR Circuit Breakers Required.

# INSTALLATION INSTRUCTIONS

## A. Precautions

### ⚠ WARNING

Improper installation may damage equipment, could endanger life, cause serious injury and/ or property damage.

1. Read Installation and Operating Instructions carefully before attempting to start your air conditioner installation.
2. Dometic Corporation will not be liable for any damages or injury incurred due to failure in following these instructions.
3. Installation must comply with the National Electrical Code ANSI/NFPA-70 and CSA Standard C22.1 (latest edition and any State or Local Codes or regulations).
4. **DO NOT** add any devices or accessories to this air conditioner except those specifically authorized by Dometic.
5. This equipment must be serviced by qualified personnel and some states require these people to be licensed.

## B. Choosing Proper Location For The Air Conditioner

This air conditioner is specifically designed for installation on the roof of a recreational vehicle (RV). When determining your cooling requirements, the following should be considered:

- Size of RV;
  - Window area (increases heat gain);
  - Amount of insulation in walls and roof;
  - Geographical location where the RV will be used;
  - Personal comfort level required.
1. Normal Location-The air conditioner is designed to fit over an existing roof vent opening.

FIG. 1

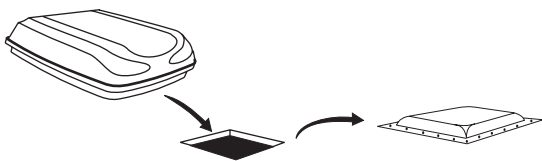

2. Other Locations-When no roof vent is available or another location is desired, the following is recommended:
  - a. For one unit installation: The air conditioner should be mounted slightly forward of center (front to back) and centered from side to side.

- b. For two unit installations: Install one Air Conditioner 1/3 and one Air Conditioner 2/3's from front of RV and centered from side to side.

FIG. 2

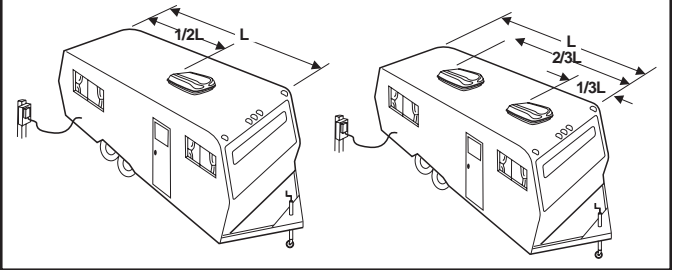

It is preferred that the air conditioner be installed on a relatively **flat and level** roof section measured with the RV parked on a level surface.

**Note:** A 8° slant to **either** side, or front to back, is acceptable for all units.

3. After Location Has Been Selected:
  - a. Check for obstructions in the area where air conditioner will be installed. See FIG. 3 & 4.
  - b. The roof must be designed to support 130 pounds when the RV is in motion. Normally a 200 lb. static load design will meet this requirement.

### CAUTION

It is the responsibility of the installer of this air conditioner system to ensure structural integrity of the RV roof. Never create a low spot on the roof where water will collect. Water standing around the air conditioner may leak into the interior causing damage to the product and the RV.

- c. Check inside the RV for return air kit obstructions (i.e. door openings, room dividers, curtains, ceiling fixtures, etc.) See FIG. 3 & 4.

FIG. 3

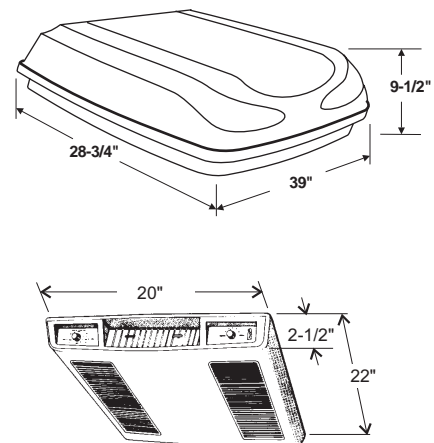

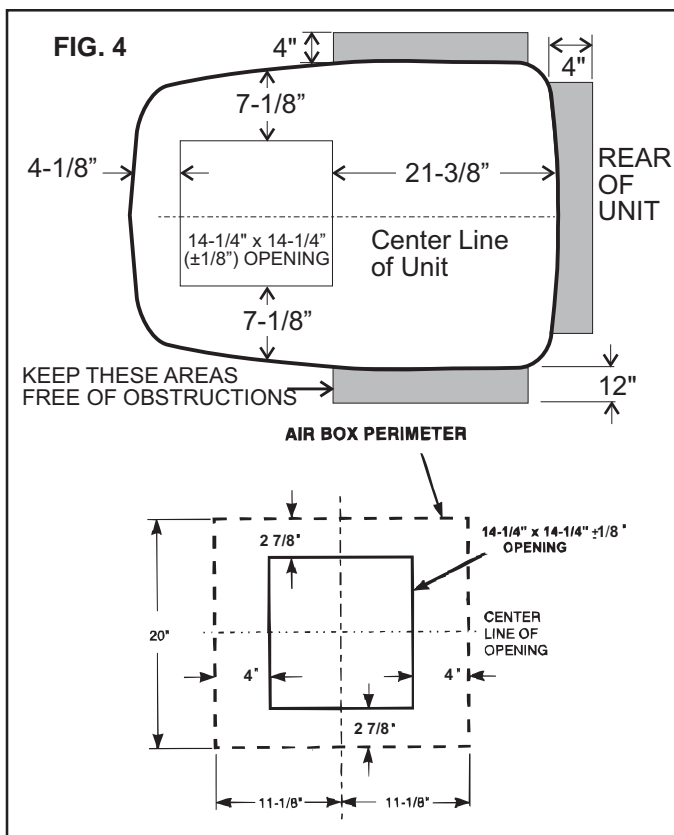

### C. Roof Preparation

1. Opening Requirements - Before preparing the ceiling opening, read all of the following instructions before beginning the installation. If a roof vent opening will not be used a 14-1/4" x 14-1/4" (±1/8") opening must be cut through the roof and ceiling of the RV. This opening must be located between the roof reinforcing members.

#### **⚠ WARNING**

There may be electrical wiring between the roof and the ceiling. Disconnect 120 volt AC power cord and the positive (+) 12 volt DC terminal at the supply battery. Failure to follow this instruction may create a shock hazard causing death or severe personal injury.

The 14-1/4" x 14-1/4" (±1/8") opening is part of the return air system of the Air Conditioner and must be finished in accordance with NFPA Standard 501C Section 2.7.2.

2. Roof Vent Removal
  - a. Unscrew and remove the roof vent.
  - b. Remove all caulking compound around opening.
  - c. Seal all screw holes and seams where the roof gasket is located. Use a good grade of all weather sealant. See FIG. 5.

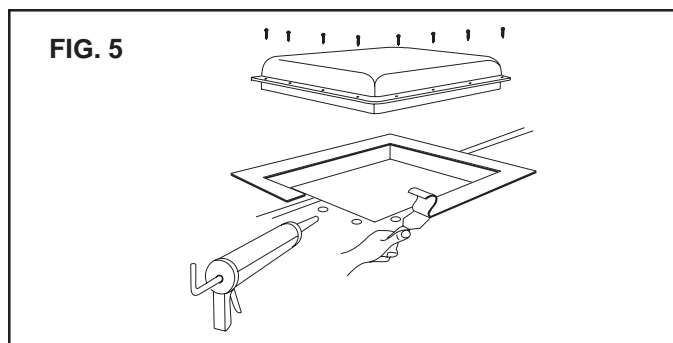

- d. If the opening exceeds 14-3/8" x 14-3/8", it will be necessary to re-size the opening to 14-1/4" x 14-1/4" (±1/8").
  - e. If the opening is less than 14-1/8" x 14-1/8", it must be enlarged.
3. New Opening- (Installation Other Than Vent Opening)
    - a. Mark a 14-1/4" x 14-1/4" (±1/8") square on the roof and carefully cut the opening.
    - b. Using the roof opening as a guide, cut the matching hole in the ceiling.
    - c. The opening created must be framed to provide adequate support and prevent air from being drawn from the roof cavity. Lumber 3/4" or more in thickness must be used. Remember to provide an entrance hole for power supply.

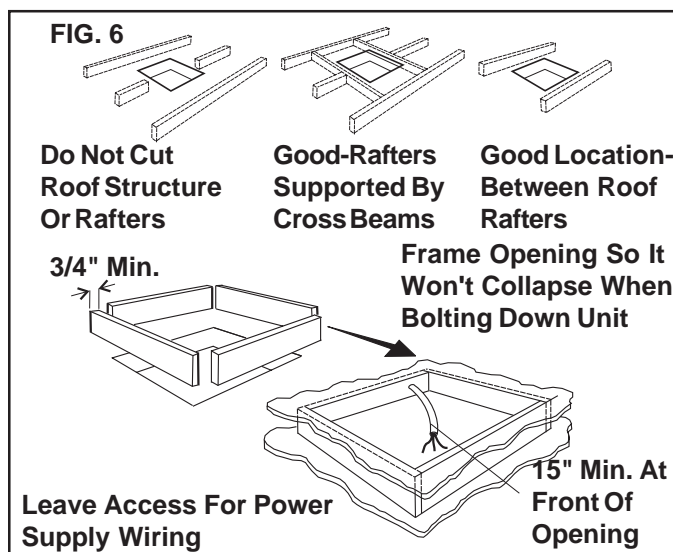

#### **CAUTION**

It is the responsibility of the installer of this air conditioner system to ensure structural integrity of the RV roof. Never create a low spot on the roof where water will collect. Water standing around the air conditioner may leak into the interior causing damage to the product and the RV.

## D. Wiring Requirements

1. 120 VAC Supply Line  
Route a copper 12 AWG, with ground, 120 VAC supply line from the time delay fuse or circuit breaker box to the roof opening.
  - a. This supply line must be located in the front portion of the 14-1/4" x 14-1/4" ( $\pm 1/8$ ") opening.
  - b. The power **MUST** be on a separate 20 Amp time delay fuse or HACR circuit breaker.
  - c. Make sure that at least 15" of supply wire extends into the roof opening. This ensures and easy connection at the junction box.
  - d. Wiring must comply with all National, State and Local Wiring Codes.
  - e. Use a steel sleeve and a grommet or equivalent methods to protect the wire where it passes into the opening.

## E. Placing Air Conditioner On The Roof

### ⚠ CAUTION

This unit weighs approximately 100 pounds. To prevent back injury, use a mechanical hoist to place Air Conditioner on roof.

1. Remove the air conditioner from the carton and discard carton. See FIG. 7.

FIG. 7

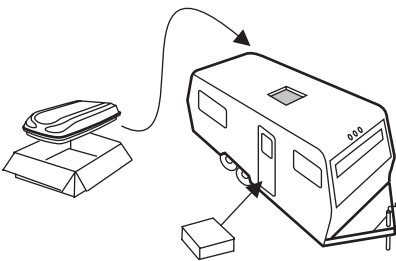

2. Place the air conditioner on the roof.
3. Lift and place the unit over the prepared opening using the gasket on the unit as a guide. See FIG. 8.

FIG. 8

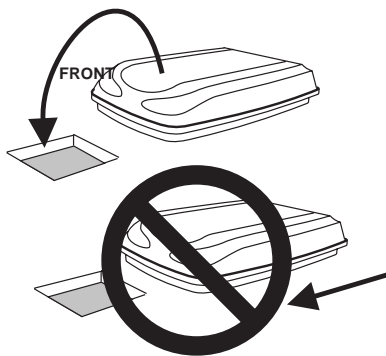

### CAUTION

Do not slide the unit. This may damage the roof gasket attached to the bottom and may create a leaky installation.

4. Place the 3106152.006 Mechanical Air Distribution Box Kit. This box contains mounting hardware for the air conditioner and will be used inside the RV. This completes the outside work. Minor adjustments can be done from the inside of the RV if required.

## F. Installing The Air Conditioner

1. Remove air box and mounting hardware from carton. The upper duct is shipped inside the lower duct which is part of the ceiling template.
2. Check for correct alignment and adjust the unit as necessary (Roof Gasket centers over 14-1/4"  $\pm 1/8$ " opening).
3. Remove upper duct from ceiling template and locate it over blower discharge. See FIG. 9.

**Note:** Edge without flange installs toward REAR of opening.

FIG. 9

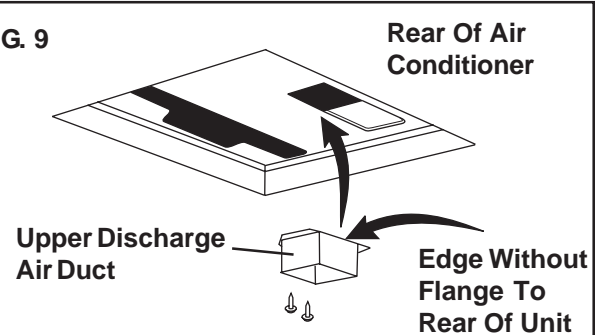

4. Use two (2) sharp pointed #10 sheet metal screws to hold duct to base pan. Screw holes are provided in bottom of base pan for these screws.
5. Reach up into return air opening of the air conditioner and pull the unit electrical cord down for later connection.
6. Measure the ceiling to roof thickness:
  - a. If distance is 1"-2", remove perforated tabs from both upper and lower ducts. See FIG. 10.
  - b. If distance is 2"-3", remove perforated tabs from bottom duct only. See FIG. 10.
  - c. If distance is 3"-4", install ducts as received. See FIG. 10.
  - d. If distance is 4"-6", use optional 318556.000 Duct Adaptor and 3100895.006 Bolt Kit. See FIG. 10.

FIG. 10

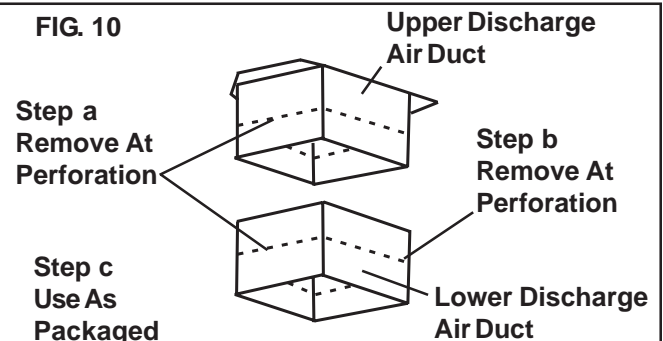

7. Install ceiling template by sliding lower duct over upper duct. See FIG. 11.

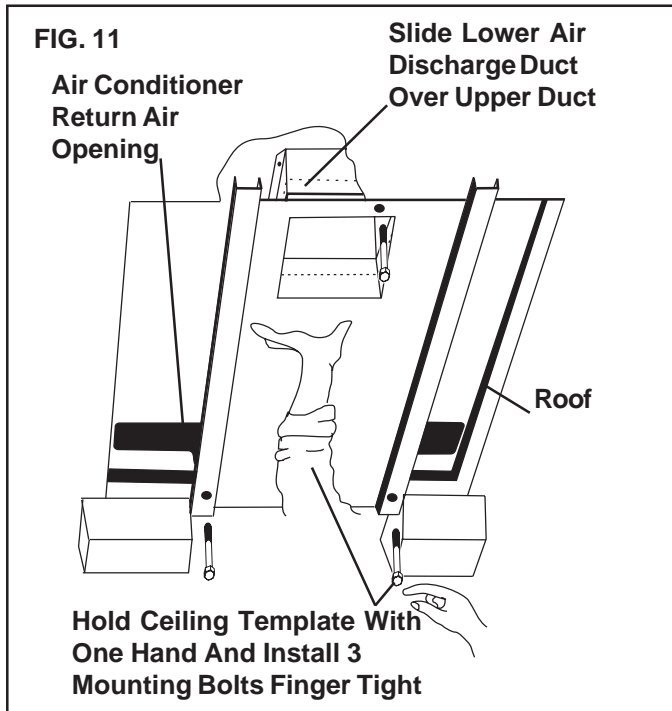

8. Hold the ceiling template with one hand and with the other, install the three 1/4" mounting bolts through the template and into the base pan.
- Finger-tighten the bolts and check alignment. There should be an equal opening on each side and the rear flange must be tight against the roof opening.
  - EVENLY** tighten the three bolts to a torque of 40 to 50 inch pounds. This will compress the roof gasket to approximately 1/2". The bolts are self locking so over tightening is not necessary.

### CAUTION

If bolts are left loose there may not be an adequate roof seal or if over tightened, damage may occur to the air conditioner base or ceiling template. Tighten to torque specifications listed in this manual.

## G. Wiring The System

### ! WARNING

Disconnect 120 volt AC. Failure to follow these instructions could create a shock hazard causing death or severe personal injury.

Reach up into the return air opening and pull the remaining wires down.

- Connection of 120 VAC (refer to FIG. 12)

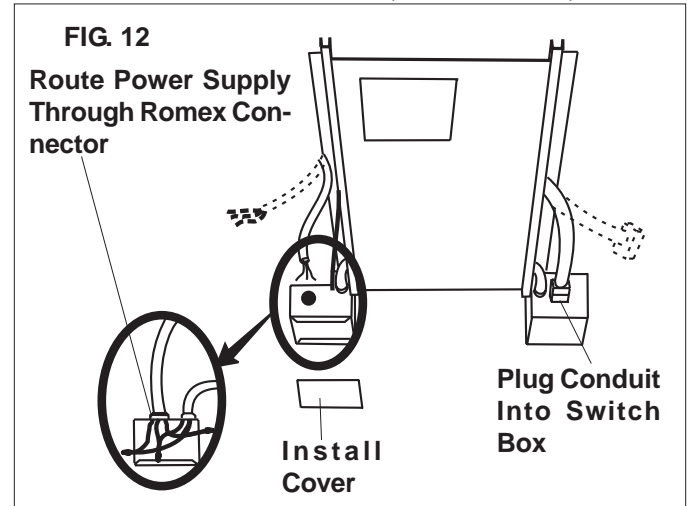

- Route power supply line through Romex connector into junction box. Tighten connector, being careful not to pinch or short wires.
- Connect white to white; black to black; and green to green or bare copper wire using appropriate sized twist connectors.
- Tape the twist wire connectors to the supply wire to assure they don't vibrate off.
- Push the wires into the box.
- Install the cover onto the junction box.
- Plug the electrical conduit from the upper unit into the mating switch box connector. See FIG. 12.

## H. Air Distribution Box Installation

1. Remove the two return air grills and filters.
2. Slide the front end of the air box over the shafts of the thermostat and selector switch. See FIG.13.

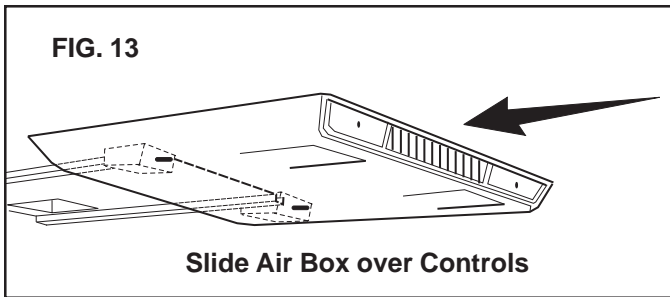

3. Install four screws through legs in air box into the pre-punched holes in the ceiling template.
4. Install the return air grills and filters by simply pushing them into place.
5. Install the two knobs provided on the ends of the thermostat and selector switch shafts.
6. The power supply to the air conditioner may now be turned "ON".
7. Your air conditioner is now installed and ready for operation. Please read the following instructions before attempting to run the unit.

## OPERATING INSTRUCTIONS

### A. Controls

1. The Selector Switch has ten positions including "OFF". This controls fan speed, heating mode, and cooling modes. See FIG. 14.

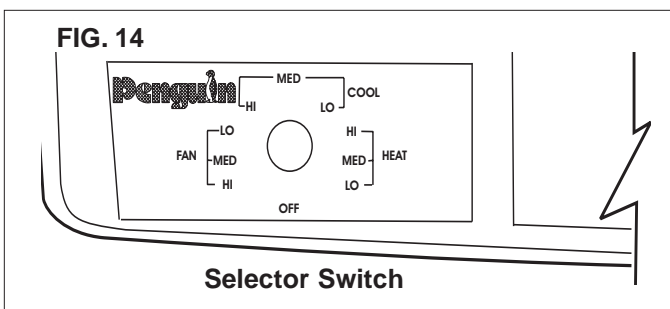

2. The thermostat controls the compressor ON/OFF operation in cooling temperature range of 65° to 90°F. See FIG. 15.

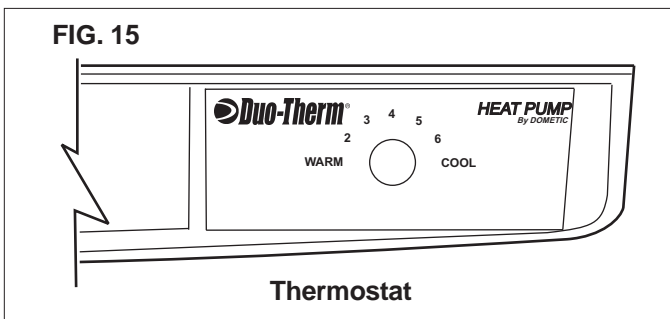

## B. Cooling Operation

1. Set the thermostat at the desired temperature level.
2. Select the fan speed that best satisfies your needs:
  - a. **HIGH COOL:** Selected when maximum cooling and dehumidification required.
  - b. **MED COOL:** Selected when normal or average cooling required.
  - c. **LOW COOL:** Selected when room at desired comfort level and needs to be maintained. Normally this speed used for night time operation.

**Note:** The blower runs continuously to circulate air and maintain an even temperature. The compressor will come on as cooling is required to maintain the selected temperature level.

## C. Fan Operation:

1. This will circulate the air in your RV without cooling or heating. There are three positions: **HIGH FAN, MED FAN or LOW FAN** to select from, depending upon personal choice. See FIG. 14.

## D. Heating Operation

**NOTE:** The heat pump will not replace a furnace for heating your RV in cold weather. The intent is to warm the coach during mild winter weather.

1. Turn the selector switch to:
  - a. High heat
  - b. Med heat
  - c. Low heat
2. Set the thermostat to your comfort level.
3. The fan and compressor will come on and begin heating.
4. When the desired temperature level is reached, the compressor will cycle as required to maintain selected temperature. The blower will run continuously to circulate air and maintain an even temperature.

## E. "OFF" Position

1. This is to turn Unit off.

## G. Customer Maintenance

1. Periodically remove the return air filter located above the removable panel in the air box. Wash the filter with soap and warm water, let dry and the reinstall.

**Note:** Never run the air conditioner without return air filter in place. This may plug the unit evaporator coil with dirt and may substantially affect the performance of the unit.

2. Clean air box housing and control panel with a soft cloth dampened with a mild detergent. Never use furniture polish or scouring powders.
3. The blower motor is Factory lubricated and requires no service under normal use.



4. Under certain conditions, frost may form on the evaporator coil. If this should occur, inspect the filter and clean if dirty. Make sure air louvers are not obstructed. Air conditioners have a greater tendency to frost when the outside temperature is relatively low. This may be prevented by adjusting the thermostat control knob to a warmer setting (counter clockwise). Should frosting continue, operate on MED, or HIGH FAN only setting until the cooling coil is free of frost.
5. If your unit fails to operate or operated improperly, check the following before calling your service center.
  - a. If RV connected to motor generator, check to be sure motor generator is running and producing power.
  - b. If RV connected to power supply by a land line, check to be sure line is sized properly to run air conditioner load and it is plugged into power supply.
  - c. Check your fuse or circuit breaker to see if it is open.
  - d. If the outside temperature is below 40° F the Ambient Thermostat will prevent operation of the compressor until the temperature is above 45° F.
  - e. After the above checks, call your local service center for further help. This unit must serviced by qualified service personnel only.
6. When calling for service, always give the following:
  - a. Air Conditioner Model and Serial Number found on rating plate located on base pan of air conditioner bottom.
  - b. Air Distribution Box Kit Part and Serial Number found on rating plate located on ceiling template. Observe this rating plate through the air box filter grill opening.

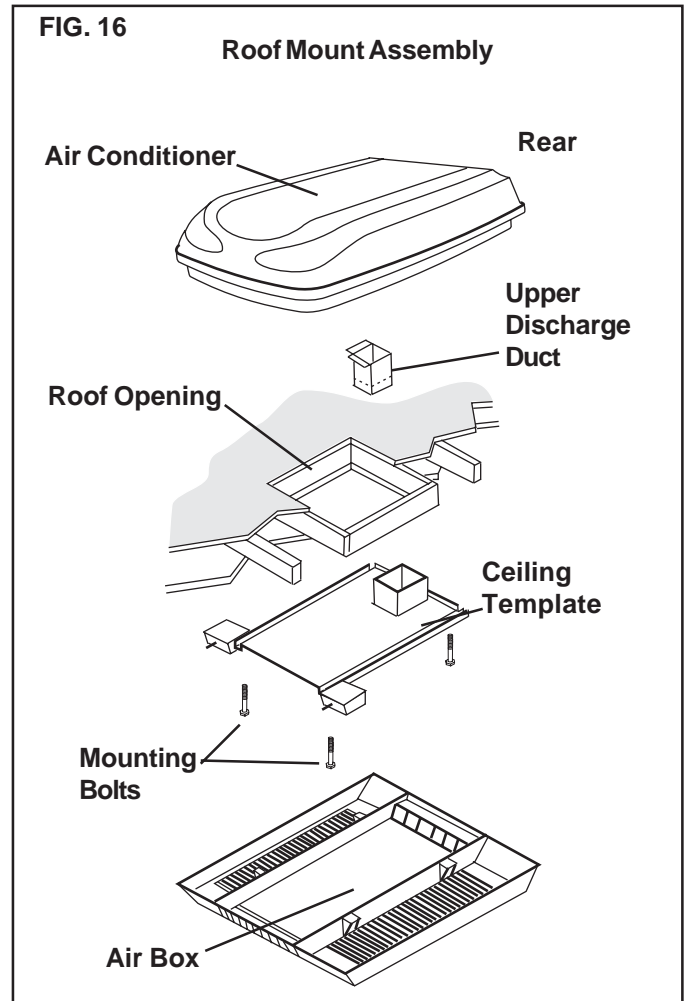

### UNIT WIRING DIAGRAM

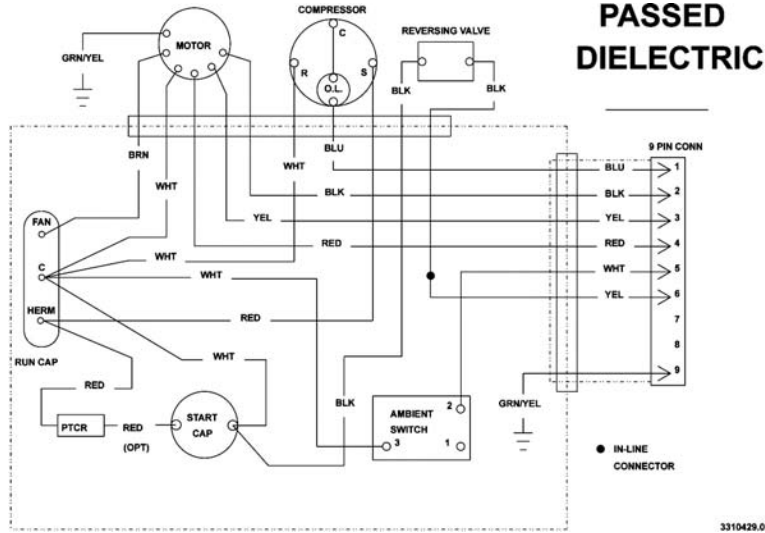

### AIR BOX WIRING DIAGRAM

