

AQUAJET RV Pump

Model: 5503-4V15-B636

IDENTIFYING THE PART NUMBER:

5503-4V15-B636

- BASEPLATE AS SHOWN
8 = 2.25 X 3.18 FOOTPRINT
- 12VDC MOTOR
- DOUBLE BALL BEARING MOTOR
- FOR RV AND MARINE APPLICATIONS
- TASTE FREE MATERIALS (SEE BELOW)
- 65 PSI SHUT-OFF SAFETY SWITCH
- 12VDC SPEED CONTROLLER
- 3.5 DEGREE CAM
- QUICK DISCONNECT PORTS, 3/4" DIAMETER
- SERIES 550 PUMP

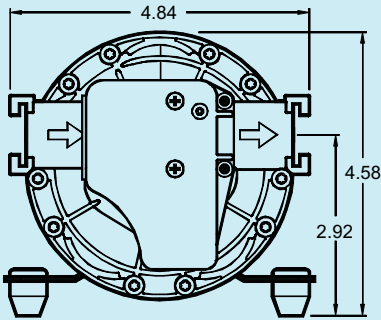

SPECIFICATIONS:

- MOTOR:**
TYPE: 12 VDC, Permanent Magnet, Totally Enclosed, Non-Ventilated
LEADS: 14 AWG, 12" Long, Black Negative, Red Positive
DO NOT REVERSE
TEMP. LIMITS: Safe to 150°F (66°C)
DUTY CYCLE: See Heat Rise Graph
- SPEED CONTROLLER:** Factory Set to Approximately 10 Amps Max. Thermally Protected to Avoid Component Damage.
CAUTION: Exterior Surfaces (heat sink), May Exceed 150°F After Only 5 Minutes of Operation.
- PUMP DESIGN:** 5 Chamber Diaphragm Pump, Self Priming, Capable of Being Run Dry
- TYPICAL APPLICATION:** Water Pressurization for RV and Marine
- MATERIALS:**
PUMP HOUSINGS: Polypropylene
CONTROLLER HOUSING: Nylon
VALVES: EPDM
DIAPHRAGM: Santoprene
FASTENERS: Stainless Steel
- LIQUID TEMPERATURE:** 140°F (60°C) Max.
- PUMP CERTIFICATIONS:** IAPMO, NSF
- PRIMING CAPABILITIES:** 13 Feet
- FITTINGS:**

TYPE	SHAPE	HOSE BARB SIZE		
		1/2"	5/8"	3/4"
HOSE BARB	STRAIGHT	QBS-554	QBS-555	QBS-556
HOSE BARB	ELBOW	QBE-554	QBE-555	QBE-556
THREADED FOR USE WITH PRE-FILTER				QTS-556

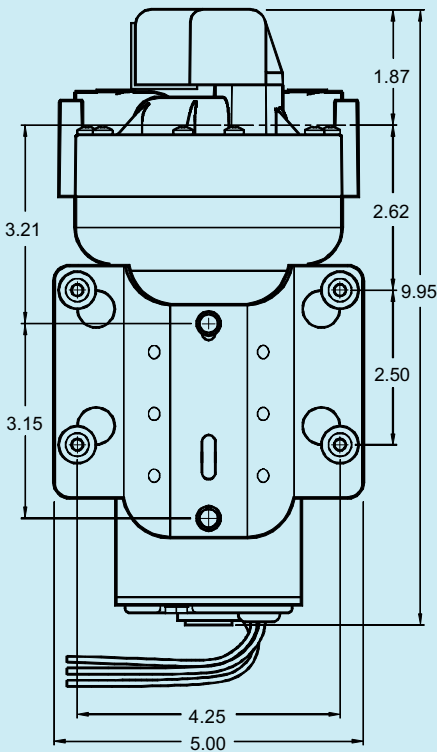

WEIGHT: 8 lbs.



Aquatec Water Systems, Inc.
 17422 Pullman
 Irvine, CA 92614
 Sales: 949-225-2200
 Fax: 949-225-2222

www.aquatec.com

DOCUMENT: DS5503-4V15-B636
 ISSUED: 3/3/00
 REVISED: 3/3/00

AQUAJET RV Pump

Model: 5503-4V15-B636

PERFORMANCE DATA				
DISCHARGE PRESSURE		FLOW		CURRENT
(PSI)	(BAR)	(GPM)	(LPM)	(AMPS)
65	4.4	0.70	2.65	10.00
60	4.0	1.00	3.78	10.00
50	3.4	1.50	5.78	10.00
40	2.7	2.20	8.32	10.00
30	2.0	2.80	10.50	10.00
20	1.4	3.80	14.36	9.70
10	0.7	4.50	17.01	8.40
OPEN	OPEN	5.00	18.90	7.20

PERFORMANCE MEASURED WITH FLOODED INLET (0 PSI), 70°F (21°C) AMBIENT AND WATER TEMPERATURE, AND VOLTAGE CONTROLLED AT 12 VDC. POSITIVE INLET PRESSURE WILL INCREASE THE DISCHARGE PRESSURE BY A SIMILAR AMOUNT, FOR A GIVEN FLOW. MAXIMUM INLET PRESSURE IS 60 PSI.

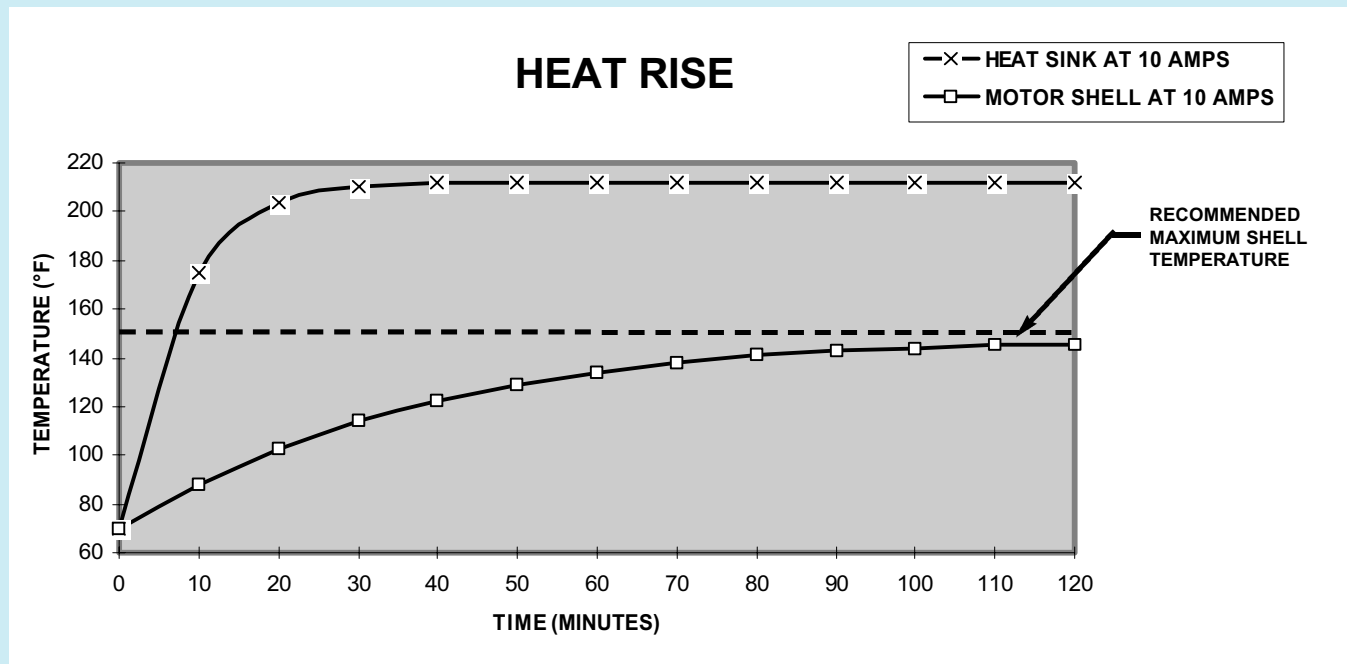

The Aquajet RV Pump operates in the shaded area, and is therefore capable of sustaining continual running, at any of the above listed pressures, without shutting down to allow the motor to cool. The Speed Controller generates heat much faster, as evidenced by the heat sink temperature rise and must be protected from accidental human contact. The Speed Controller is equipped with a thermal protector that protects the electronic components in case of extreme temperatures. After sufficient cool down, the system will re-start

ALL PERFORMANCE AND HEAT RISE FIGURES ARE APPROXIMATE. ACTUAL VALUES WILL VARY WITH AMBIENT CONDITIONS.